

1. (40%) Consider the two thin positive lenses and the thin negative lens in your optics kit (these are the so-called “tombstone” lenses, named for the shape of the plastic holder). If you do not have these lenses, you can borrow mine for a short time.

- (a) Experimentally determine the diameters and *approximate* focal lengths of the lenses; you may use any method but tell how you did it (note emphasis on “approximate” – this does not have to be exact, I’m more interested in how you figured it out).

First, we will assume that these are “thin lenses”, so the principal points coincide with the vertices. Recall the definition of “focal points” – these are the points where light from a source at ∞ comes to a focus. I measured the focal lengths of the positive lenses by finding the point where the light from a “distant” source comes to a focus and measured the approximate diameters with a ruler. For the positive lenses, these measurements are shown in the table. Now, what about the negative lens? We can’t measure the distance to a virtual focal point with a ruler. But we can make a telescope with the negative lens that has an unknown focal length at a positive lens with a known focal length. The distance between the lenses is the sum of the focal lengths. The length of a telescope formed from lens A and lens C is

$$f_A + f_C \simeq 97 \text{ mm} \implies f_C \simeq 97 \text{ mm} - 120 \text{ mm} = -23 \text{ mm}$$

Lens	f	Diameter
A	120 mm	31 mm
B	30 mm	16 mm
C	-23 mm	16 mm

- (b) Use these lenses to design two different kinds of magnifying telescope. Specify the system parameters you used in your telescopes.

1. *The only free parameter available for the system is the separation between the lenses, which for a telescope is the sum of the focal lengths:*

$$\text{Keplerian} : t_{AB} = f_A + f_B = 120 \text{ mm} + 30 \text{ mm} = 150 \text{ mm}$$

$$\text{Galilean} : t_{AC} = f_A + f_C = 120 \text{ mm} - 23 \text{ mm} = 97 \text{ mm}$$

- (c) For both types of telescope, locate and determine the transverse magnification of the images obtained by both telescopes of an object located 500 mm in front of the first lens, i.e., $\overline{OV} = 500 \text{ mm}$.

Since these are “telescopes”, the focal points and principal points are located at ∞ . We can’t use them to find the image but rather must go through the lenses “step by step” using the thin-lens imaging equation.

1. For the Keplerian telescope, the distance calculations are:

$$\begin{aligned}
 \frac{1}{s_A} + \frac{1}{s'_A} &= \frac{1}{f_A} \\
 \implies s'_A &= \left(\frac{1}{f_A} - \frac{1}{s_A} \right)^{-1} = \left(\frac{1}{120 \text{ mm}} - \frac{1}{500 \text{ mm}} \right)^{-1} \\
 &= \frac{3000}{19} \text{ mm} \simeq 157.9 \text{ mm} \\
 t &= s_B + s'_A \\
 \implies s_B &= t - s'_A = 150 \text{ mm} - \frac{3000}{19} \text{ mm} = -\frac{150}{19} \text{ mm} \simeq -7.9 \text{ mm} \\
 \frac{1}{s_B} + \frac{1}{s'_B} &= \frac{1}{f_B} \\
 \implies s'_B &= \overline{\mathbf{V'O'}} = \left(\frac{1}{f_B} - \frac{1}{s_B} \right)^{-1} = \left(\frac{1}{30 \text{ mm}} - \frac{1}{-\frac{150}{19} \text{ mm}} \right)^{-1} \\
 &= +\frac{25}{4} \text{ mm} = \boxed{6.25 \text{ mm}}
 \end{aligned}$$

The magnifications of the images from the lenses are:

$$\begin{aligned}
 (M_T)_A &= -\frac{s'_A}{s_A} = -\frac{\frac{3000}{19} \text{ mm}}{500 \text{ mm}} = -\frac{6}{19} \\
 (M_T)_B &= -\frac{s'_B}{s_B} = -\frac{+\frac{25}{4} \text{ mm}}{-\frac{150}{19} \text{ mm}} = +\frac{19}{24}
 \end{aligned}$$

The magnification of the system is the product of the individual magnifications:

$$M_T = (M_T)_A \cdot (M_T)_B = -\frac{6}{19} \cdot +\frac{19}{24} = \boxed{M_T = -\frac{1}{4}}$$

The image is inverted and “minified”

2. For the Galilean telescope, the distance calculation for the first lens is the same:

$$\begin{aligned}
 \frac{1}{s_A} + \frac{1}{s'_A} &= \frac{1}{f_A} \\
 \implies s'_A &= \left(\frac{1}{f_A} - \frac{1}{s_A} \right)^{-1} = \left(\frac{1}{120 \text{ mm}} - \frac{1}{500 \text{ mm}} \right)^{-1} \\
 &= \frac{3000}{19} \text{ mm} \simeq 157.9 \text{ mm}
 \end{aligned}$$

The distance from the image generated by the first lens to the second lens is:

$$\begin{aligned}
 t &= s_C + s'_A \\
 \implies s_C &= t - s'_A = 97 \text{ mm} - \frac{3000}{19} \text{ mm} = -\frac{1157}{19} \text{ mm} \simeq -60.9 \text{ mm} \\
 \frac{1}{s_C} + \frac{1}{s'_C} &= \frac{1}{f_C} \\
 \implies s'_C &= \overline{\mathbf{V'O'}} = \left(\frac{1}{f_C} - \frac{1}{s_C} \right)^{-1} = \left(\frac{1}{-23 \text{ mm}} - \frac{1}{-\frac{1157}{19} \text{ mm}} \right)^{-1} \\
 &= -\frac{26611}{720} \text{ mm} \simeq \boxed{37.0 \text{ mm}}
 \end{aligned}$$

The magnifications of the images from the lenses are:

$$\begin{aligned}
 (M_T)_A &= -\frac{s'_A}{s_A} = -\frac{\frac{3000}{19} \text{ mm}}{500 \text{ mm}} = -\frac{6}{19} \\
 (M_T)_C &= -\frac{s'_C}{s_C} = -\frac{-\frac{26611}{720} \text{ mm}}{-\frac{1157}{19} \text{ mm}} = -\frac{437}{720}
 \end{aligned}$$

The magnification of the system is the product of the individual magnifications:

$$M_T = (M_T)_A \cdot (M_T)_C = -\frac{6}{19} \cdot -\frac{437}{720} = \frac{23}{120} \simeq \boxed{+0.19 = M_T}$$

So the image is upright and “minified”.

- (d) For both types of telescope, locate and find the magnification of the image created by the second lens of the first lens – you might want to try the experiment with your lenses to see this image.

This is very easy; we just have to find the image of an object located a distance t in front of the second lens:

1. *Keplerian:*

$$\begin{aligned}
 \frac{1}{t} + \frac{1}{s'_B} &= \frac{1}{f_B} \\
 \implies s'_B &= \left(\frac{1}{f_B} - \frac{1}{t} \right)^{-1} = \left(\frac{1}{30 \text{ mm}} - \frac{1}{150 \text{ mm}} \right)^{-1} = \frac{75}{2} \text{ mm} = \boxed{37.5 \text{ mm}} \\
 M_T &= -\frac{s'_B}{t} = -\frac{37.5 \text{ mm}}{150 \text{ mm}} = \boxed{-0.25}
 \end{aligned}$$

Because the diameter of the first lens is 31 mm, the size of the “image” is

$$-0.25 \cdot 31 \text{ mm} = -7.75 \text{ mm}$$

The “image” of the stop (the exit pupil) is inverted and located 37.5 mm “behind” the eye lens – the exit pupil is “real”.

2. Galilean:

$$\begin{aligned} \frac{1}{t} + \frac{1}{s'_C} &= \frac{1}{f_C} \implies s'_C = \left(\frac{1}{f_C} - \frac{1}{t} \right)^{-1} = \left(\frac{1}{-23 \text{ mm}} - \frac{1}{97 \text{ mm}} \right)^{-1} \\ &= -\frac{2231}{120} \text{ mm} \simeq \boxed{-18.6 \text{ mm}} \\ M_T &= -\frac{s'_C}{t} = -\frac{-\frac{2231}{120} \text{ mm}}{97 \text{ mm}} = +\frac{23}{120} \simeq \boxed{0.19} \end{aligned}$$

- (e) Now change the separation of the lenses in the the Galilean telescope to create a telephoto lens. You may base this lens design on the one we modelled in class, but you are free to choose any lens separation that produces a “telephoto”.

You have freedom to choose t here. From the example in class, we know that the distance between the positive and negative lens for a telephoto is LESS than that for a telescope. Instead of $t = f_A + f_C = 97 \text{ mm}$, I'll pick $t = 90 \text{ mm}$ first (and find out that it gives the wrong answer!), and then I'll pick $t = 100 \text{ mm} > f_A + f_C$ and find out that it gives a better answer.

- (f) For your telephoto design, find the focal points and principal points of the system, locate the image of an object located 500 mm in front of the first lens, and find its magnification.

$$\begin{aligned} f_{eff} &= \left(\frac{1}{f_A} + \frac{1}{f_C} - \frac{t}{f_A f_C} \right)^{-1} = \frac{f_A \cdot f_C}{f_A + f_C - t} = \frac{120 \text{ mm} \cdot -23 \text{ mm}}{120 \text{ mm} - 23 \text{ mm} - 90 \text{ mm}} \\ &= -\frac{2760}{187} \text{ mm} \simeq -394.3 \text{ mm} \end{aligned}$$

OOPS, the focal length is negative – this is NOT a telephoto lens. Since the numerator is negative because $f_C < 0$, then we have to choose t to be large enough so that the denominator is negative too, thus $t > f_A + f_C$, e.g., $t = \overline{\mathbf{V}\mathbf{V}'} = +100 \text{ mm}$

$$\begin{aligned} f_{eff} &= \left(\frac{1}{f_A} + \frac{1}{f_C} - \frac{t}{f_A f_C} \right)^{-1} = \frac{f_A \cdot f_C}{(f_A + f_C) - t} = \frac{120 \text{ mm} \cdot -23 \text{ mm}}{120 \text{ mm} - 23 \text{ mm} - 100 \text{ mm}} \\ &= \boxed{+920 \text{ mm} = f_{eff}} \end{aligned}$$

Now find the image-space and object-space focal points from the BFD and FFD:

$$\begin{aligned} BFD &\equiv \overline{\mathbf{V}'\mathbf{F}'} = \frac{f_C (f_A - t)}{(f_A + f_C) - t} = \frac{-23 \text{ mm} \cdot (120 \text{ mm} - 100 \text{ mm})}{-3 \text{ mm}} = +\frac{460}{3} \text{ mm} \\ &\simeq \boxed{+153.3 \text{ mm}} \\ FFD &\equiv \overline{\mathbf{F}\mathbf{V}} = \frac{f_A (f_C - t)}{(f_A + f_C) - t} = \frac{120 \text{ mm} \cdot (-23 \text{ mm} - 100 \text{ mm})}{-3 \text{ mm}} \\ &= \boxed{+4920 \text{ mm}} \text{ (WAY out in front)} \end{aligned}$$

We know the definition of the effective (equivalent) focal length is:

$$f_{eff} \equiv \overline{\mathbf{F}\mathbf{H}} = \overline{\mathbf{H}'\mathbf{F}'}$$

so the image-space principal point is located one focal length in front of the image-space focal point:

$$\begin{aligned}\overline{H'F'} &= 920 \text{ mm} = \overline{H'V'} + \overline{V'F'} = \overline{H'V'} + BFD \\ \overline{H'V'} &= 920 \text{ mm} - \frac{460}{3} \text{ mm} = \frac{2300}{3} \text{ mm} = 767\frac{2}{3} \text{ mm}\end{aligned}$$

$$\begin{aligned}\overline{FH} &= \overline{FV} + \overline{VH} \\ \overline{VH} &= \overline{FH} - \overline{FV} = \overline{FH} - FFD \\ \overline{VH} &= +920 \text{ mm} - 4920 \text{ mm} = -4000 \text{ mm} \\ \text{so } \overline{HV} &= +4000 \text{ mm}\end{aligned}$$

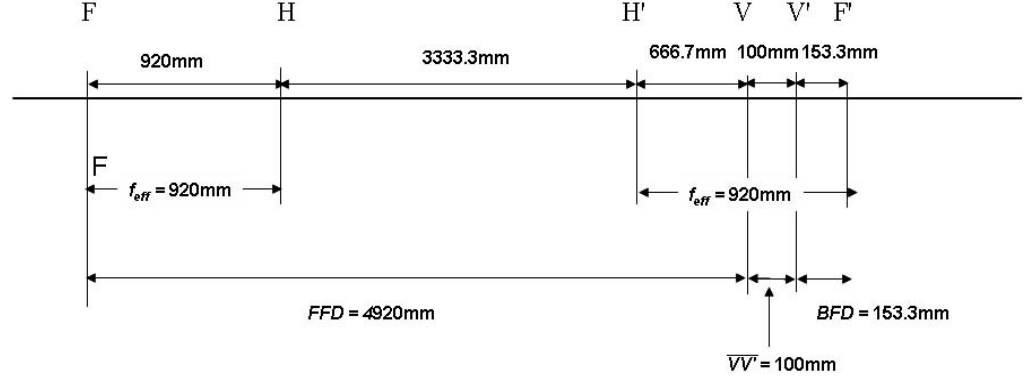

We can locate the image and find its magnification either by “brute force” (finding the image and magnification created by each lens in turn) or by using the thin-lens formula with the distances measured from the principal points. I’ll use the latter:≈

$$\begin{aligned}\overline{OH} &= \overline{OV} + \overline{VH} \\ &= 500 \text{ mm} + (-4000 \text{ mm}) = -3500 \text{ mm}\end{aligned}$$

$$\begin{aligned}\frac{1}{\overline{OH}} + \frac{1}{\overline{H'O'}} &= \frac{1}{f_{eff}} \\ \overline{H'O'} &= \left(\frac{1}{f_{eff}} - \frac{1}{\overline{OH}} \right)^{-1} = \left(\frac{1}{920 \text{ mm}} - \frac{1}{-3500 \text{ mm}} \right)^{-1} \\ &= \frac{161\,000}{221} \text{ mm} \simeq 728.5 \text{ mm}\end{aligned}$$

$$\begin{aligned}\overline{H'O'} &= \overline{H'V'} + \overline{V'O'} \\ \overline{V'O'} &= \overline{H'O'} - \overline{H'V'} = \frac{161\,000}{221} \text{ mm} - \frac{2300}{3} \text{ mm} \\ &= -\frac{25\,300}{663} \text{ mm} \simeq \boxed{-38.2 \text{ mm} = \overline{V'O'}}\end{aligned}$$

The image is virtual! The transverse magnification is:

$$M_T = -\frac{\overline{H'O'}}{\overline{OH}} = -\frac{\frac{161\,000}{221} \text{ mm}}{-3500 \text{ mm}} = \frac{46}{221} \simeq \boxed{0.208 = M_T}$$

Now try the same calculation by “brute force”: the distance from the object to the first lens is 500 mm:

$$s'_1 = \left(\frac{1}{f_A} - \frac{1}{s_1} \right)^{-1} = \left(\frac{1}{120 \text{ mm}} - \frac{1}{500 \text{ mm}} \right)^{-1} = \frac{3000}{19} \text{ mm} \simeq 157.9 \text{ mm}$$

The transverse magnification is:

$$(M_T)_1 = -\frac{s'_1}{s_1} = -\frac{\frac{3000}{19} \text{ mm}}{500 \text{ mm}} = -\frac{6}{19} \simeq -0.316$$

The separation of the lenses is $t = 100 \text{ mm}$, so the object distance for the second lens is:

$$s_2 = t - s'_1 \simeq -57.9 \text{ mm}$$

The image distance from the second lens is:

$$s'_2 = \left(\frac{1}{f_C} - \frac{1}{s_2} \right)^{-1} = \left(\frac{1}{-23 \text{ mm}} - \frac{1}{-57.9 \text{ mm}} \right)^{-1} \simeq -38.2 \text{ mm}$$

which agrees with the value obtained using the principal points. The transverse magnification from the second lens is:

$$(M_T)_2 = -\frac{s'_2}{s_2} = -\frac{-38.2 \text{ mm}}{-57.9 \text{ mm}} \simeq -0.66$$

The total magnification is:

$$(M_T)_1 \cdot (M_T)_2 \simeq (-0.316) \cdot (-0.66) \simeq 0.208$$

which again agrees with the calculation via principal points.

AGAIN, THESE MEASUREMENTS ARE ONLY VALID FOR MY DESIGN OF A TELEPHOTO LENS – YOURS WILL BE DIFFERENT UNLESS YOU HAPPENED TO MEASURE THE SAME FOCAL LENGTHS AND SELECT THE SAME DISTANCE t .

- (g) Now “reverse” the lens so that the negative lens is in front, but use the same separation as in the telephoto. Locate both principal and focal points of the “reversed” lens and find both focal distances.

If you reverse the lens, everything reverses! (YAWN)

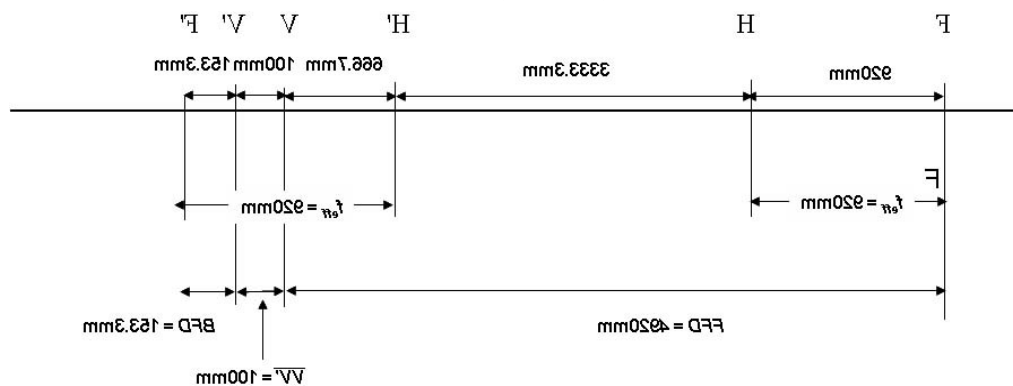

(Chuckle)

Seriously, if you reverse the system, the focal length remains the same and the principal points and vertices “swap”:

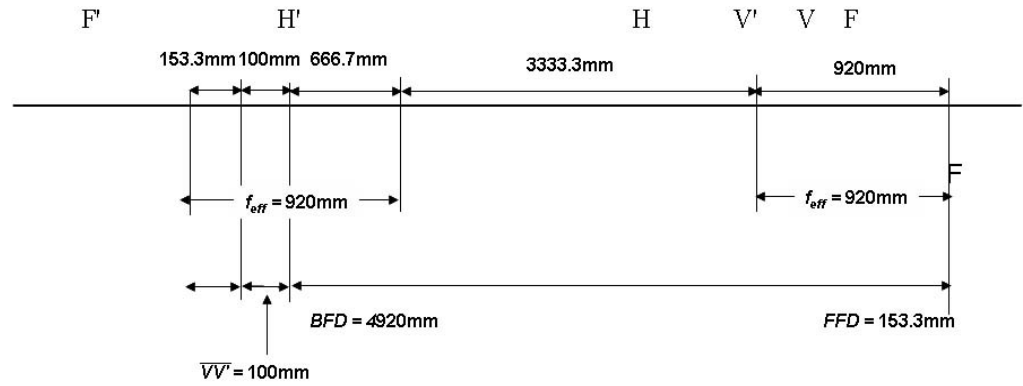

Layout of “reversed telephoto”

- (h) Find the image of an object located 500 mm in front of the first lens of the reversed telephoto and find its magnification.

We can use the same equations as for the telephoto, but we have to measure the distances from the appropriate principal points:

$$\begin{aligned}\overline{\text{OH}} &= \overline{\text{OV}} + \overline{\text{VH}} \\ &= 500 \text{ mm} + \frac{2300}{3} \text{ mm} = \frac{3800}{3} \text{ mm} = 1266\frac{2}{3} \text{ mm}\end{aligned}$$

$$\begin{aligned}\frac{1}{\overline{\text{OH}}} + \frac{1}{\overline{\text{H}'\text{O}'}} &= \frac{1}{f_{eff}} \\ \overline{\text{H}'\text{O}'} &= \left(\frac{1}{f_{eff}} - \frac{1}{\overline{\text{OH}}} \right)^{-1} = \left(\frac{1}{920 \text{ mm}} - \frac{1}{\frac{3800}{3} \text{ mm}} \right)^{-1} \\ &= \frac{43\,700}{13} \text{ mm} \simeq +3361.54 \text{ mm}\end{aligned}$$

$$\begin{aligned}\overline{\text{H}'\text{O}'} &= \overline{\text{H}'\text{V}'} + \overline{\text{V}'\text{O}'} \\ \overline{\text{V}'\text{O}'} &= \overline{\text{H}'\text{O}'} - \overline{\text{H}'\text{V}'} = \frac{43\,700}{13} \text{ mm} - (-4000 \text{ mm}) \\ &= \frac{95\,700}{13} \text{ mm} \simeq \boxed{+7361.5 \text{ mm} = \overline{\text{V}'\text{O}'}}\end{aligned}$$

$$M_T = -\frac{\overline{\text{H}'\text{O}'}}{\overline{\text{OH}}} = -\frac{\frac{43\,700}{13} \text{ mm}}{\frac{3800}{3} \text{ mm}} = -\frac{69}{26} \simeq -2.65$$

- (i) Scale this model reversed lens to make a system with $BFD \equiv \overline{\text{V}'\text{F}'} = 35 \text{ mm}$ instead of the value you obtained in the previous section. Determine the focal length, focal distances, etc.

In the paraxial case, everything is linear, so we just scale all dimensions by the ratio:

$$\frac{(\overline{\text{V}'\text{F}'})_{new}}{(\overline{\text{V}'\text{F}'})_{old}} = \frac{35 \text{ mm}}{4920 \text{ mm}} \simeq 0.007$$

so the “new” equivalent focal length is

$$(f_{eff})_{new} = (f_{eff})_{old} \cdot \frac{35}{4920} = 920 \text{ mm} \cdot \frac{35}{4920} = \frac{805}{123} \text{ mm} = \boxed{+6.54 \text{ mm} = f_{eff}}$$

This is VERY SHORT, much less than the new BFD of 35 mm

$$\begin{aligned} (BFD)_{new} &= 35 \text{ mm} \\ (FFD)_{new} &= (FFD)_{old} \cdot \frac{35}{4920} = 153\frac{1}{3} \text{ mm} \cdot \frac{35}{4920} = \frac{805}{738} \text{ mm} \simeq 1.1 \text{ mm} \\ f_C &= -23 \text{ mm} \cdot \frac{35}{4920} \simeq -0.16 \text{ mm} \\ f_A &= +120 \text{ mm} \cdot \frac{35}{4920} \simeq -0.85 \text{ mm} \end{aligned}$$

- (j) Graph the image distance from the vertex ($\overline{V'O'}$) as a function of the object distance from the vertex (\overline{OV}) for the scaled reversed lens.

We can easily plot the image distance measured from the principal point as a function of the object distance from the principal point:

$$\begin{aligned} \overline{H'O'} &= s' \simeq \left(\frac{1}{+6.54 \text{ mm}} - \frac{1}{\overline{OH}} \right)^{-1} = \left(\frac{1}{+6.54 \text{ mm}} - \frac{1}{s} \right)^{-1} \\ s' &= \left(\frac{1}{+6.54 \text{ mm}} - \frac{1}{s} \right)^{-1} \end{aligned}$$

To graph the distances measured from the vertices, we just have to add the appropriate factors

$$\begin{aligned} \overline{V'O'} &= \overline{H'O'} - \overline{H'V'} = \overline{H'O'} - 4000 \text{ mm} \cdot \frac{35}{4920} \simeq s' - 28.5 \text{ mm} \\ \overline{OV} &= \overline{OH} - \overline{HV} = s + \overline{VH} = s + 766\frac{2}{3} \text{ mm} \cdot \frac{35}{4920} \simeq s + 5.5 \text{ mm} \\ s &= \overline{OV} - 5.5 \text{ mm} \\ s' &= \overline{V'O'} + 28.5 \text{ mm} \end{aligned}$$

:

$$\begin{aligned} s' &= \overline{V'O'} + 28.5 \text{ mm} = \left(\frac{1}{+6.54 \text{ mm}} - \frac{1}{\overline{OV} - 5.5 \text{ mm}} \right)^{-1} \\ \Rightarrow \overline{V'O'} &= \left(\frac{1}{+6.54 \text{ mm}} - \frac{1}{\overline{OV} - 5.5 \text{ mm}} \right)^{-1} - 28.5 \text{ mm} \end{aligned}$$

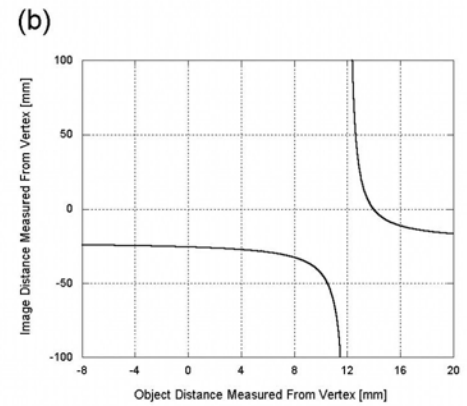
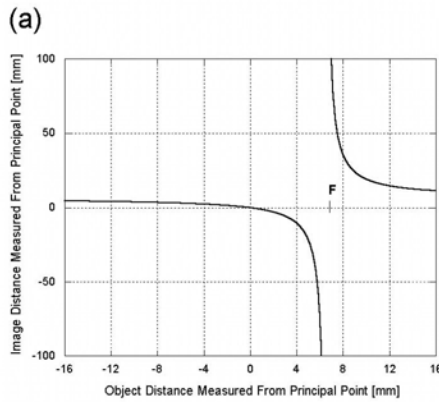

Graph (a) is just included for information and shows the image distance as a function of object distance when measured from the principal points. If the object is located at **F** (the object-space focal point), then the image is at ∞ . If the object distance is 0 (object at **H**), then the image distance is also 0 (image at **H'**). If the object distance is larger than the focal length, then the image distance is positive. Graph (b) shows the image distance measured from the image-space vertex **V'** as a function of the object distance measured from the object-space vertex **V**. Note that the image of an object located approximately 14 mm in front of the front vertex appears at the rear vertex, which may be confirmed by substituting $\overline{OV} = 14$ mm into the equation for s' .

- (k) (OPTIONAL BONUS) Determine and justify a useful application for the reversed lens.

The reversed telephoto gives us a lens with a short focal length but a large back focal distance, it is akin to a “fisheye” lens. It gives a lot of “room” from the rear vertex to the focal point but still has a short focal length. Note that we have *ONLY* looked at the paraxial properties of the lens and have said nothing about image “quality”, which will depend on the aberrations.

2. (20%) I am nearsighted, which means I need a negative corrective lens positioned at the front (object-space) focal point of my eye. My particular prescription requires a lens with a *power* of -3.25 diopters.

- (a) Design a lens made of glass with $n = 1.5$ that will give the necessary correction if used in air.

Lensmaker's equation applies in air:

$$\begin{aligned}\frac{1}{f} &= (n_2 - 1) \left(\frac{1}{R_1} - \frac{1}{R_2} \right) \\ -3.25 \text{ m}^{-1} &= 0.5 \left(\frac{1}{R_1} - \frac{1}{R_2} \right) \\ \left(\frac{1}{R_1} - \frac{1}{R_2} \right) &= -6.5 \text{ m}^{-1}\end{aligned}$$

We can select any pair of radii that satisfy this equation. If we make the lens "equiconcave", so that both surfaces have the same radius of curvature, though in different directions, then $R_1 < 0$ and $R_2 > 0$:

$$\begin{aligned}\left(\frac{1}{-|R|} - \frac{1}{+|R|} \right) &= \left(-\frac{2}{|R|} \right) = -6.5 \text{ m}^{-1} \\ \implies |R| &= \frac{2}{6.5 \text{ m}^{-1}} = 307.69 \text{ mm} = |R| = 307.69 \text{ mm} \\ \boxed{R_1 = -307.69 \text{ mm}, R_2 = +307.69 \text{ mm}}\end{aligned}$$

- (b) I also like to swim and need swimming goggles that give me the same correction. Design the lens for swimming goggles made of the same glass that will have the same power when used in water AND when used in air.

Now we can't use the lensmaker's equation because the object space is in water and the image space is in air (between the back side of the goggle lens and my eye). We still assume that the lens is thin:

$$\frac{1}{f} = \varphi = \left(\frac{n_2 - n_1}{R_1} \right) + \left(\frac{n_3 - n_2}{R_2} \right) = -3.25 \text{ m}^{-1}$$

Outside the pool, the object space is air with $n_1 = 1$; in the water, $n_1 = 1.33$.

$$\begin{aligned}\text{Object space in air} &: \frac{1}{f} = \left(\frac{1.5 - 1}{R_1} \right) + \left(\frac{1 - 1.5}{R_2} \right) \\ \text{Object space in water} &: \frac{1}{f} = \left(\frac{1.5 - 1.33}{R_1} \right) + \left(\frac{1 - 1.5}{R_2} \right) \\ \left(\frac{1.5 - 1}{R_1} \right) + \left(\frac{1 - 1.5}{R_2} \right) &= \left(\frac{1.5 - 1.33}{R_1} \right) + \left(\frac{1 - 1.5}{R_2} \right) \\ \text{cancel the common terms} &: : \\ \implies \left(\frac{1.5 - 1}{R_1} \right) &= \left(\frac{1.5 - 1.33}{R_1} \right)\end{aligned}$$

which can only be true if both terms are 0, so that $R_1 = \infty$. In other words, we select the curvature of the front surface to have infinite radius (i.e., it is flat). The power of the first surface is 0 diopters, and thus all of the power of the lens is contributed by the second surface:

$$\frac{1}{f} = 0 + \left(\frac{1 - 1.5}{R_2} \right) = -\frac{0.5}{R_2} = -3.25 \text{ m}^{-1}$$
$$R_2 = \frac{1}{6.5} \text{ m} \simeq +0.154 \text{ m} = +154 \text{ mm}$$

$$\boxed{R_1 = \infty, R_2 = +154 \text{ mm}}$$

3. (15%) Consider a thin lens with $R_1 = +200\text{ mm}$ and $R_2 = +150\text{ mm}$ made of glass with $n = 1.5$.

(a) Sketch the lens.

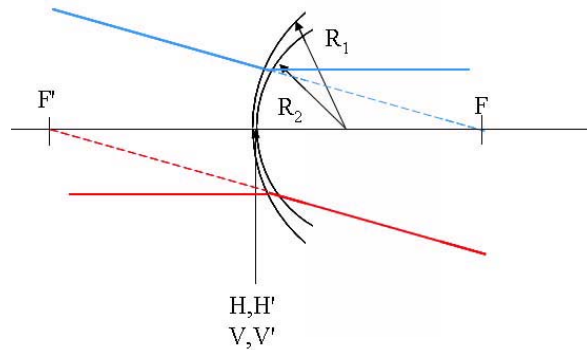

This is a “meniscus” lens – the two surfaces curve in the same direction.

- (b) Locate the focal and principal points of this lens on the sketch, including labels of all relevant distances.

$$\frac{1}{f} = (n_2 - 1) \left(\frac{1}{R_1} - \frac{1}{R_2} \right) = 0.5 \cdot \left(\frac{1}{200\text{ mm}} - \frac{1}{150\text{ mm}} \right)$$

$$f = \left(0.5 \cdot \left(\frac{1}{200\text{ mm}} - \frac{1}{150\text{ mm}} \right) \right)^{-1} = \boxed{f = -1200\text{ mm}}$$

Because lens is thin, vertices and principal points coincide at the lens. The power of the lens is negative even though the first surface has positive curvature (because the second surface has a shorter radius and thus more curvature).

- (c) Locate the image of an object placed 400 mm in front of the first surface, so that $\overline{\mathbf{OV}} = +400\text{ mm}$. Determine the transverse magnification.

$$s = 400\text{ mm}$$

$$s' = \left(\frac{1}{-1200\text{ mm}} - \frac{1}{400\text{ mm}} \right)^{-1} = \boxed{s' = -300\text{ mm}}$$

$$M_T = \frac{-s'}{s} = -\frac{-300\text{ mm}}{400\text{ mm}} = \boxed{M_T = +\frac{3}{4}}$$

- (d) Locate the image of an object placed 400 mm “behind” the second surface. Determine the transverse magnification.

Note that this is a “virtual object” so the object rays converge from the left side to a point 400 mm behind the lens on the right side.

$$s = -400\text{ mm}$$

$$s' = \left(\frac{1}{-1200\text{ mm}} - \frac{1}{-400\text{ mm}} \right)^{-1} = \boxed{s' = +600\text{ mm}}$$

$$M_T = \frac{-s'}{s} = -\frac{+600\text{ mm}}{-400\text{ mm}} = \boxed{M_T = +\frac{3}{2}}$$

(e) Repeat (a), (b), and (c) for the case where the object space and image space are “glass” with $n = 1.5$, but the lens is “made” of air with $n = 1.0$.

$$\begin{aligned}
 \frac{n_1}{s_1} + \frac{n_3}{s_2} &= \frac{1.5}{s_1} + \frac{1.5}{s_2} = \frac{1}{f} \implies 1.5 \left(\frac{1}{s_1} + \frac{1}{s_2} \right) = \frac{1}{f} \\
 &= (n_2 - n_1) \left(\frac{1}{R_1} - \frac{1}{R_2} \right) = (1 - 1.5) \left(\frac{1}{R_1} - \frac{1}{R_2} \right) \\
 &= -0.5 \cdot \left(\frac{1}{200 \text{ mm}} - \frac{1}{150 \text{ mm}} \right) \\
 \frac{f}{1.5} &= \left(0.5 \cdot \left(\frac{1}{200 \text{ mm}} - \frac{1}{150 \text{ mm}} \right) \right)^{-1} = +1200 \text{ mm} \\
 &\boxed{f = +1800 \text{ mm}}
 \end{aligned}$$

$$\begin{aligned}
 \frac{1.5}{400 \text{ mm}} + \frac{1.5}{s_2} &= (1 - 1.5) \left(\frac{1}{200 \text{ mm}} - \frac{1}{150 \text{ mm}} \right) \\
 \frac{1}{400 \text{ mm}} + \frac{1}{s_2} &= \frac{(1 - 1.5)}{1.5} \left(\frac{1}{200 \text{ mm}} - \frac{1}{150 \text{ mm}} \right) \\
 s_2 &= \left(\frac{(1 - 1.5)}{1.5} \left(\frac{1}{200 \text{ mm}} - \frac{1}{150 \text{ mm}} \right) - \frac{1}{400 \text{ mm}} \right)^{-1} = \boxed{s_2 \simeq -514.29 \text{ mm}} \\
 M_T &= -\frac{-514.29 \text{ mm}}{400 \text{ mm}} = \boxed{M_T \simeq +1.29}
 \end{aligned}$$

:

$$\begin{aligned}
 \frac{1.5}{-400 \text{ mm}} + \frac{1.5}{s_2} &= (1 - 1.5) \left(\frac{1}{200 \text{ mm}} - \frac{1}{150 \text{ mm}} \right) \\
 \frac{1}{-400 \text{ mm}} + \frac{1}{s_2} &= \frac{(1 - 1.5)}{1.5} \left(\frac{1}{200 \text{ mm}} - \frac{1}{150 \text{ mm}} \right) \\
 s_2 &= \left(\frac{(1 - 1.5)}{1.5} \left(\frac{1}{200 \text{ mm}} - \frac{1}{150 \text{ mm}} \right) + \frac{1}{400 \text{ mm}} \right)^{-1} = \boxed{s_2 \simeq +327.27 \text{ mm}} \\
 M_T &= -\frac{+327.27 \text{ mm}}{400 \text{ mm}} = \boxed{M_T \simeq -0.82}
 \end{aligned}$$

4. (15%) We discussed how a “quarter-wave plate” delays the phase of light polarized along one direction measured relative to light with the orthogonal polarization. The “fast” axis is that aligned with the polarization that has the smaller refractive index. If the thickness of a quarter-wave plate is doubled, we (naturally) have a “half-wave plate”. Determine the effect of a half-wave plate on incident linearly polarized light that is oriented at an angle θ relative to the “fast” axis.

The index of refraction along the “fast axis” is lower than that along the slow axis. We know that if the light is polarized along the direction of the fast axis or along that of the slow axis, then the light traverses the plate at the speed determined by the index of refraction, and so it goes “faster” if polarized along the fast axis. If the light is polarized at 45° relative to the fast axis, then we have an analogous situation to the circular polarizer. The percentage of the amplitude polarized along the fast axis is:

$$\begin{aligned} E_f \exp [i (k_0 z - \omega_0 t)] &= E_0 \exp [i (k_0 z - \omega_0 t)] \cos [\theta] = E_0 \exp [i (k_0 z - \omega_0 t)] \cos \left[\frac{\pi}{4} \right] \\ &\simeq 0.707 \cdot E_0 \exp [i (k_0 z - \omega_0 t)] \end{aligned}$$

Similarly, the percentage polarized along the slow axis is:

$$\begin{aligned} E_s \exp [i (k_0 z - \omega_0 t)] &= E_0 \exp [i (k_0 z - \omega_0 t)] \sin [\theta] = E_0 \exp [i (k_0 z - \omega_0 t)] \sin \left[\frac{\pi}{4} \right] \\ &\simeq 0.707 \cdot E_0 \exp [i (k_0 z - \omega_0 t)] \end{aligned}$$

In a half-wave plate, the phase delay of the light polarized along the slow axis is π radians.

$$\begin{aligned} \text{along fast axis} &: 0.707 \cdot E_0 \exp \left[i \left(\frac{2\pi}{\lambda_0} n_f z_0 - \omega_0 t \right) \right] \\ \text{along slow axis} &: 0.707 \cdot E_0 \exp \left[i \left(\frac{2\pi}{\lambda_0} n_s z_0 - \omega_0 t + \pi \right) \right] = -0.707 \cdot E_0 \exp \left[i \left(\frac{2\pi}{\lambda_0} n_s z_0 - \omega_0 t \right) \right] \end{aligned}$$

Since the amplitude of the slow component is multiplied by -1 , the direction of linear polarization changed by 90° , which is twice the polarization angle of the incident light.

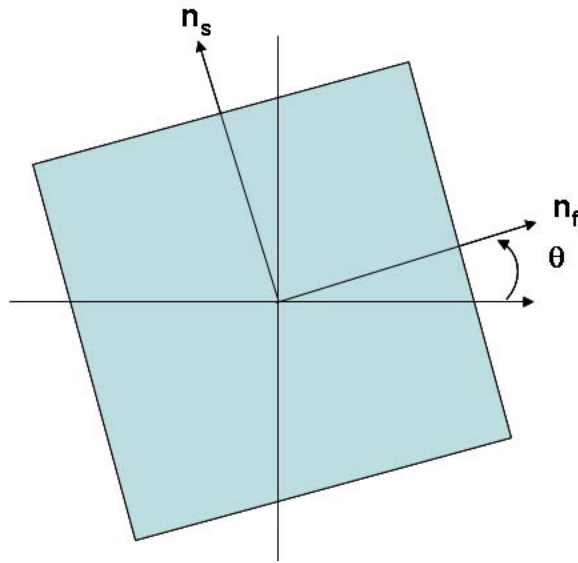

Now what about the general case? Consider that the light incident on the “front” of the half-wave plate is:

$$E [z = 0, t] = E_0 \cos [k_0 \cdot 0 - \omega_0 t] = E_0 \cos [-\omega_0 t] = E_0 \cos [\omega_0 t]$$

The plane of polarization is inclined at angle θ relative to the fast axis, so the two amplitudes are:

$$\begin{aligned} E_f &= (E_0 \cos [\omega_0 t]) \cos [\theta] \\ E_s &= (E_0 \cos [\omega_0 t]) \sin [\theta] \end{aligned}$$

After passing through the halfwave plate with thickness t and indices n_f and n_s , the amplitudes are:

$$\begin{aligned} E_f &= \left(E_0 \cos \left[\frac{2\pi n_f}{\lambda_0} t - \omega_0 t \right] \right) \cos [\theta] \\ E_s &= \left(E_0 \cos \left[\frac{2\pi n_s}{\lambda_0} t - \omega_0 t \right] \right) \sin [\theta] = \left(E_0 \cos \left[\frac{2\pi n_f}{\lambda_0} t - \omega_0 t - \pi \right] \right) \sin [\theta] \\ &= - \left(E_0 \cos \left[\frac{2\pi n_f}{\lambda_0} t - \omega_0 t \right] \right) \sin [\theta] \end{aligned}$$

So the ratios of the fields along the two axes relative to the incident field are:

$$\begin{aligned} \frac{E_f}{E_0} &= \cos \left[\frac{2\pi n_f}{\lambda_0} t - \omega_0 t \right] \cos [\theta] \\ \frac{E_s}{E_0} &= - \cos \left[\frac{2\pi n_f}{\lambda_0} t - \omega_0 t \right] \sin [\theta] \end{aligned}$$

so the component along the slow direction is multiplied by -1 , and thus the electric field is now polarized along the direction $-\theta$. In general, the polarization of a linearly polarized electric field oriented at angle θ measured from the “fast axis” is rotated by -2θ by a halfwave plate.

5. (10%) We derived two types of “magnification” of optical imaging systems: transverse and longitudinal. However, the use of the latter magnification in imaging is rather rare. Explain why this is so.

In imaging systems, we generally have a planar imaging sensor, and thus we image a “plane” of the 3-D object-space volume to the image “plane”. In such a case, the transverse magnification is significant. “Longitudinal” magnification refers to the variation in the distances between the object and the image measured “along” the optical axis, i.e., in depth. Since we can’t use this with a planar sensor, we rarely use the concept in imaging.

Statistics:

max = 87
min = 34
mean μ = 65.3
std.dev. σ = 16.2

